

# Specification Sheet

## IA80ES Industrial Washer



### IA80ES

Capacity (Dry)	8 kg
Volume	80 L
Drum Type	Sluice Drum
Door Opening	Ø 330 mm
Net Weight	135 kg
Electrical Recommendations	20 Amp – 415 Volt – 3-phase Isolating Switch at 1.8m off floor
Water Recommendations (Hot)	1x Standard 19mm Washing Machine Tap
Water Recommendations (Cold)	1x Standard 19mm Washing Machine Tap
Water Pressure	Minimum = 44PSI (3 Bar), Maximum = 72PSI (5 Bar)
Drain	Ø 76mm through floor
Foundations	Minimum 100mm M20 Grade Concrete Foundation
Optional Plinth	510 mm (height)   6 mm (thickness)   Ø 25 mm (bolt hole)

IA80c

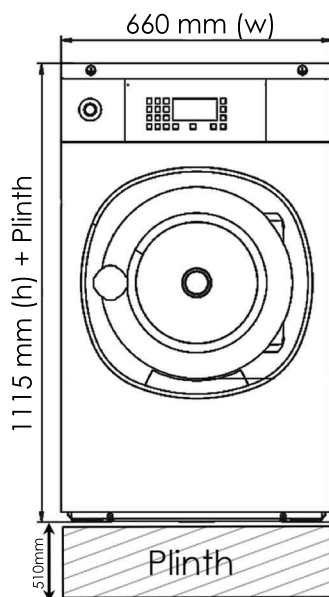

FRONT

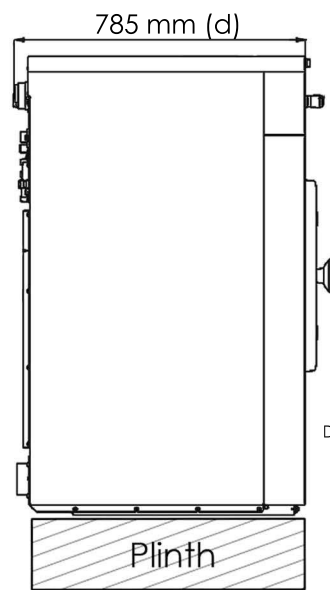

SIDE

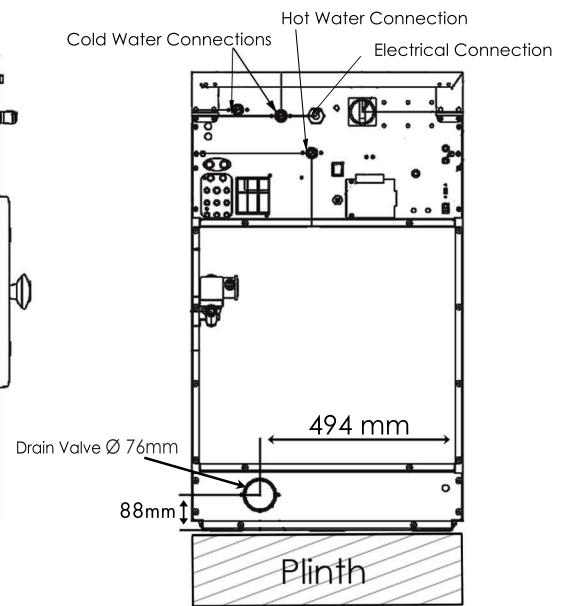

BACK



**B-Electrical**  
Services

**EnviroSaver**  
Ozone Laundry Disinfection

Tel: (08) 8337 7394  
(08) 8337 7216

[www.b-electrical.com.au](http://www.b-electrical.com.au)